

深圳市亿显国际科技有限公司 ShenZhen Yes-Display International Technology CO.,LTD.			1.44 寸液晶显示屏 1.44 Inch LCD Display Screen	
File NO.		REV	A/01	http://www.yes-display.com

SPECIFICATION FOR

Module:YS-T014401 V4.0
Item: EL010006000

Designed by	R&D Checked by	Quality Department by	Approved by

Approval by Customer:

OK

NG, Problem survey

Approved By _____

深圳市亿显国际科技有限公司 ShenZhen Yes-Display International Technology CO.,LTD.			1.44 寸液晶显示屏 1.44 Inch LCD Display Screen	
File NO.		REV	A/01	http://www.yes-display.com

Contents

List	Description	Page No.
	Cover	1
	Revision Record	2
	Contents	3
1	Technical parameters	4
2	Block Dimension	5
3	Outline Dimensions	6
4	Input terminal Pin Assignment Description	7
5	LCD Optical Characteristics	8
6	TFT Electrical Characteristics	11
7	Timing Characteristics	13
8	Inspection Standard	16
9	Reliability Test Conditions and Methods	21
10	Cautions and Handling Precautions	23
11	Packing Method	26

1. Technical parameters

ITEM	STANDARD VALUES	UNITS
LCD type	1.44" TFT	--
Dot arrangement	128(RGB)×128	dots
Color filter array	RGB vertical stripe	--
Display mode	TN / Transmission / Normally White	--
Viewing Direction	12 O'CLOCK	--
Driver IC	ST7735S	--
Module size	29.00(W)×34.41(H)×2.39(T)(Exclude FPC)	mm
Active area	25.5(W)×26.5(H)	mm
Interface	4-SPI	mm
Operating temperature	-20 ~ +70	°C
Storage temperature	-30 ~ +80	°C
Back Light	White LED*2	--

2. Block Dimension

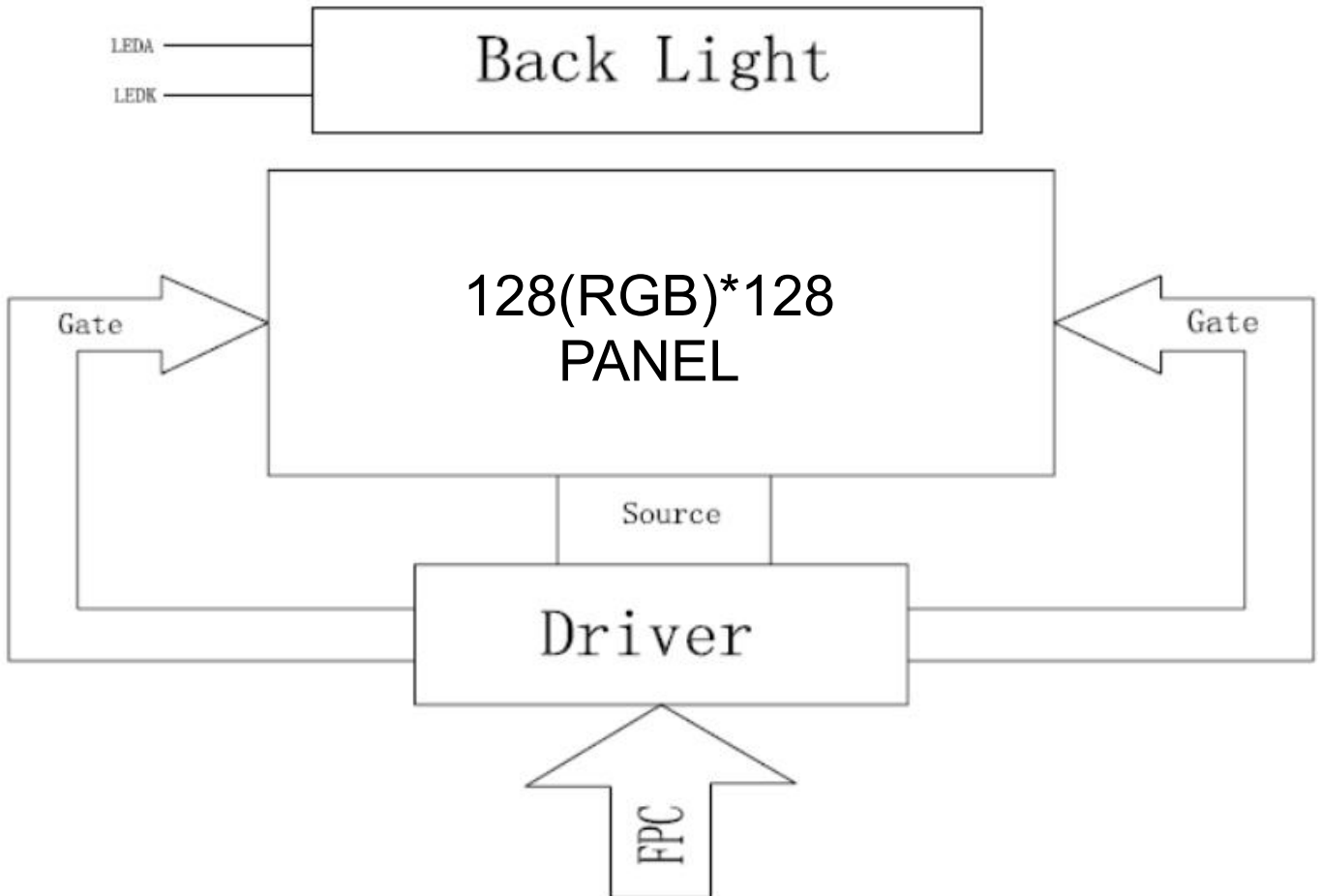

3. Outline Dimensions

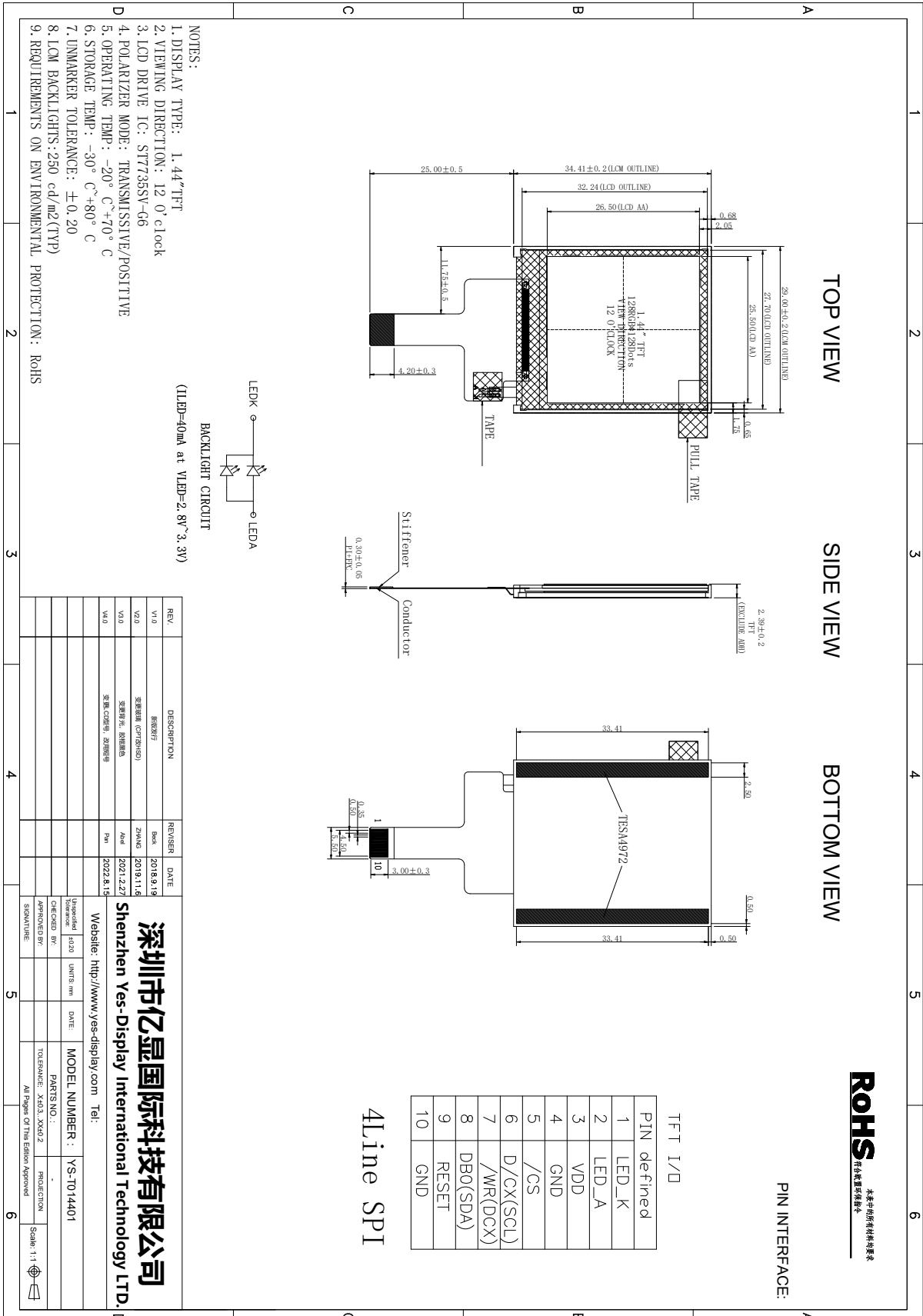

深圳市亿显国际科技有限公司 ShenZhen Yes-Display International Technology CO.,LTD.			1.44 寸液晶显示屏 1.44 Inch LCD Display Screen	
File NO.		REV	A/01	http://www.yes-display.com

4. Input terminal Pin Assignment Description

4.1 TFT Pin Description

PIN NO.	PIN NAME	DESCRIPTION
1	LEDK	LED Cathode
2	LEDA	LED Anode
3	VDD	System power supply
4	GND	System power ground.
5	CS	Chip select input pin ("Low" enable).
6	D/CX(SCL)	Display data/command Selection Pin in MCU Interface, In Serial Interface, this is used as SCL
7	WR(DCX)	Write Enable in MCU Parallel Interface, In 4-line SPI, this pin is used as D/CX (data/ command selection)
8	DB0(SDA)	DATA BUS, D0 is the serial input/output signal in serial interface mode
9	RESET	Reset signal input terminal, active at 'L'.
10	GND	System power ground.

4.2 TP Pin Description

TBD

5. LCD Optical Characteristics

Item	Symbol	Condition	Min.	Typ.	Max.	Unit	Note
Transmittance (without Polarizer)	T(%)	—	14.8	16.5	—	%	
Transmittance (with Polarizer)	T(%)	—	5.4	6.0	—	%	Measuring with EWW Polarizer · Reference Only
Contrast Ratio	CR	$\Theta=0$ Normal viewing angle	640	800	—	—	(1)(2) Measuring with EWW Polarizer · Reference Only
Response Time	Rising	T_R	—	4	8	msec	(1)(3)
	Falling	T_F	—	12	24		
Color Gamut	S(%)		—	53	—	%	
Color Chromaticity (CIE1931)	White	W_x	0.273	0.293	0.313		(1)(4) CF glass C-light
		W_y	0.305	0.325	0.345		
	Red	R_x	0.616	0.636	0.656		
		R_y	0.308	0.328	0.348		
	Green	G_x	0.263	0.283	0.303		
		G_y	0.511	0.531	0.551		
	Blue	B_x	0.115	0.135	0.155		
B_y		0.114	0.134	0.154			
Viewing Angle	Hor.	Θ_L	60	70	—		Measuring with EWW Polarizer · Reference Only
		Θ_R	60	70	—		
	Ver.	Θ_U	60	70	—		
		Θ_D	50	60	—		
Optima View Direction	12 O'clock						(5)

Note (1) Definition of Viewing Angle :

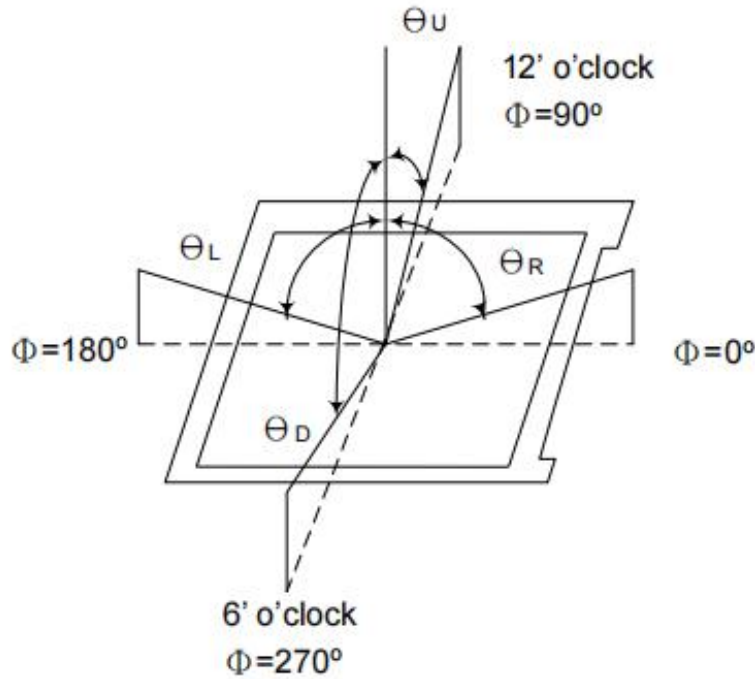

Note (2) Definition of Contrast Ratio (CR):
measured at the center point of panel

$$CR = \frac{\text{Luminance with all pixels white}}{\text{Luminance with all pixels black}}$$

Note (3) Definition of Response Time: Sum of T_R and T_F

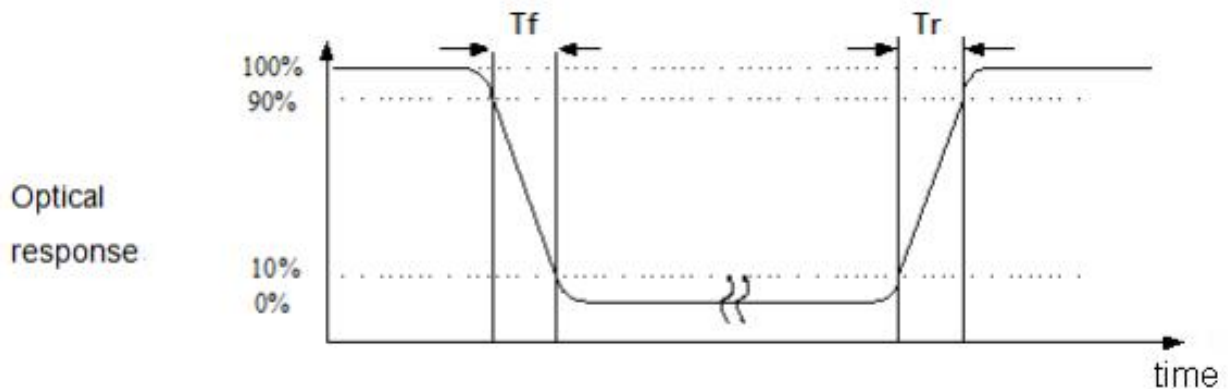

Note (4) Definition of optical measurement setup

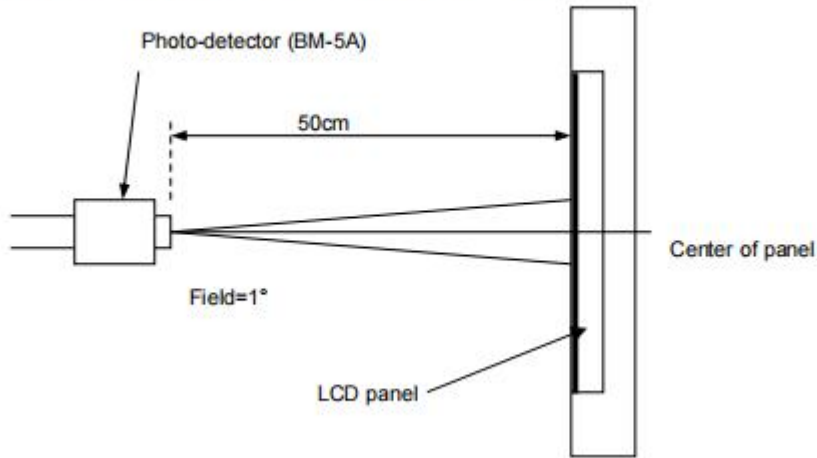

Note (5) Rubbing Direction (The different Rubbing Direction will cause the different view direction).

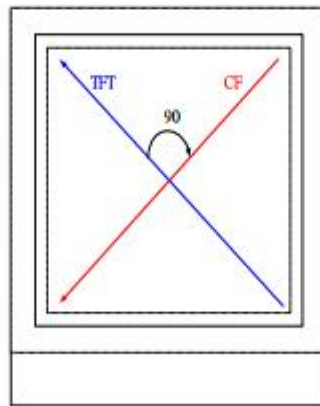

TFT Face up

6. TFT Electrical Characteristics

6.1 Absolute Maximum Ratings

Item	Symbol	Min.	Max.	Unit
Logic Supply Voltage	VDD	-0.3	4.0	V
Input Voltage	Vin	-0.3	VDD+0.3	V
Operating Temperature	T _{OP}	-20	70	°C
Storage Temperature	T _{ST}	-30	80	°C
Storage Humidity	HD	20	90	%RH

6.2 DC Characteristics

Item	Symbol	Min.	Typ.	Max.	Unit	Remark
Logic Supply Voltage	VDD	2.5	2.8	3.6	V	-
Input High Voltage	V _{IH}	0.7VDD	-	VDD	V	-
Input Low Voltage	V _{IL}	GND	-	0.3 VDD	V	-
Output High Voltage	V _{OH}	0.8 VDD	-	VDD	V	-
Output Low Voltage	V _{OL}	GND	-	0.2 VDD	V	-
I/O Leak Current	I _{LI}	-1	-	1	uA	-
Supply Current	IDD	-	TBD	-	mA	-

6.3 LED Backlight Characteristics

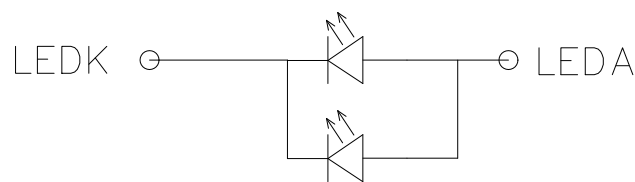

BACKLIGHT CIRCUIT

(I_{LED}=40mA at V_{LED}=2.8V~3.3V)

Item	Symbol	MIN	TYP	MAX	UNIT	Test Condition
Supply Voltage	V _f	2.8	3.2	3.6	V	I _f =40mA
Supply Current	I _f	-	40	-	mA	-
Luminous Intensity for LCM	-		250	-	cd/m ²	I _f =40mA

深圳市亿显国际科技有限公司 ShenZhen Yes-Display International Technology CO.,LTD.			1.44 寸液晶显示屏 1.44 Inch LCD Display Screen		
File NO.		REV	A/01	http://www.yes-display.com	

Uniformity for LCM	-	-	80	-	%	If=40mA
Life Time	-	-	50000	-	Hr	If=40mA
Backlight Color	White					

7. Timing Characteristics

7.1 TFT Timing Characteristics

7.1.1 Display Serial Interface Timing Characteristics (4 SPI system)

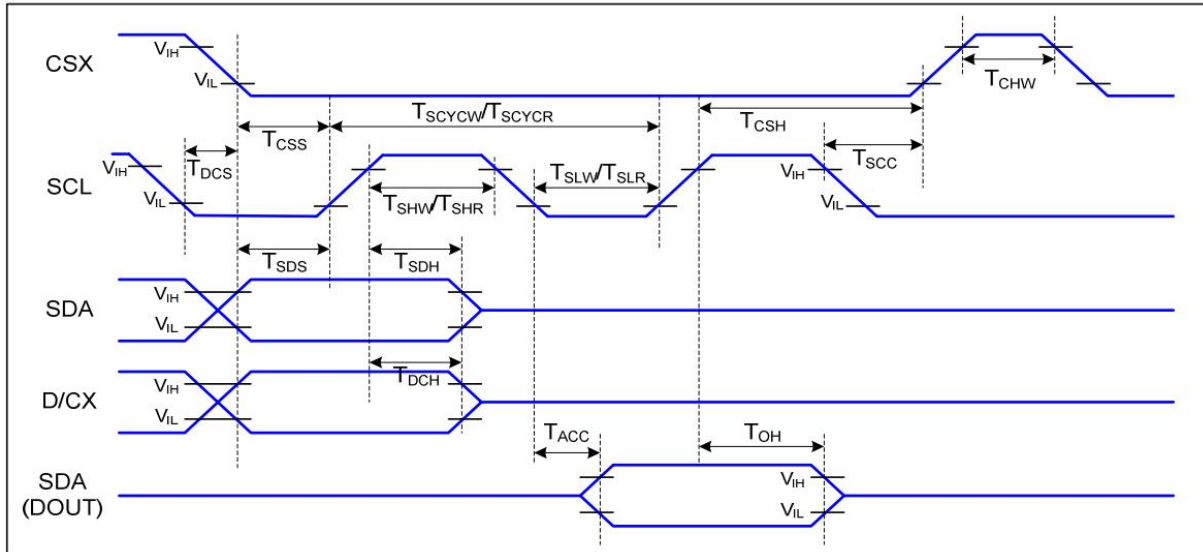

Figure 7 4-line Serial Interface Timing

Ta=25 °C, VDDI=1.65~3.7V, VDD=2.5~4.8V

Signal	Symbol	Parameter	MIN	MAX	Unit	Description
CSX	TDCS	Chip Select Setup Time (Write)	45		ns	
	TCSH	Chip Select Hold Time (Write)	45		ns	
	TDCS	Chip Select Setup Time (Read)	60		ns	
	TSCC	Chip Select Hold Time (Read)	65		ns	
	TCHW	Chip Select "H" Pulse Width	40		ns	
SCL	TSCYCW	Serial Clock Cycle (Write)	66		ns	-Write Command & Data Ram
	TSHW	SCL "H" Pulse Width (Write)	15		ns	
	TSLW	SCL "L" Pulse Width (Write)	15		ns	
	TSCYCR	Serial Clock Cycle (Read)	150		ns	-Read Command & Data Ram
	TSHR	SCL "H" Pulse Width (Read)	60		ns	
	TSLR	SCL "L" Pulse Width (Read)	60		ns	
D/CX	TDCS	D/CX Setup Time	10		ns	
	TDCH	D/CX Hold Time	10		ns	
SDA (DIN) (DOUT)	TSDS	Data Setup Time	10		ns	For Maximum CL=30pF For Minimum CL=8pF
	TSDH	Data Hold Time	10		ns	
	TACC	Access Time	10	50	ns	
	TOH	Output Disable Time	15	50	ns	

Table 7 4-line Serial Interface Characteristics

Note : The rising time and falling time (Tr, Tf) of input signal are specified at 15 ns or less. Logic high and low levels are specified as 30% and 70% of VDDI for Input signals.

7.1.2 Reset Timing Characteristics

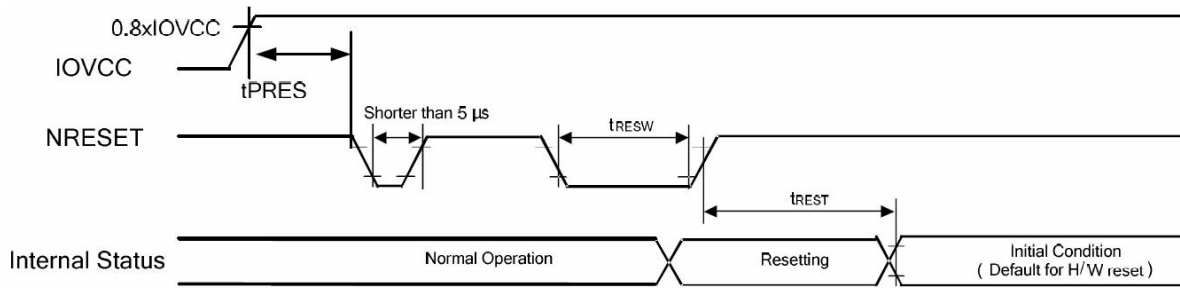

7.1.3 Power on/off timing sequence check the IC datasheet!

7.2 TP Timing Characteristics

TBD

深圳市亿显国际科技有限公司 ShenZhen Yes-Display International Technology CO.,LTD.			1.44 寸液晶显示屏 1.44 Inch LCD Display Screen	
File NO.		REV	A/01	http://www.yes-display.com

8. Inspection Standard

8.1 Incoming Inspection and Standard:

The below incoming inspection are applied to the TFT LCM Modules supplied by ShenZhen Yes-Display International Technology CO.,LTD. The customers should inspect the LCM within 14 days after receiving the goods. The result of inspection should be notified to the Seller in the writing copy promptly, if the customer do not send them within 14 days, the seller has the right to judge as acceptance of goods. The inspection lot size is treated as the quantity per shipment and per model. The sampling plan shall be inspected under MIL-STD015E in Level II by single sampling. The acceptable quality level (AQL) are categorized as below grades:

CRITICAL= 0.4%, MAJOR= 0.65%, MINOR= 1.5%

8.2 Inspection condition and Warranty policy:

The delivered LCM should be stored properly, ideally under climate-controlled environment at 25 (±5) degree Celsius as well as 60% (±10) Relative Humidity. The LCM shall be inspected in the viewing angle of 45 degree from the four major angles (U/D/L/R) under the single fluorescent lamp of 20W (equal to 300 to 500 lux). For warranty, ShenZhen Yes-Display International Technology CO.,LTD. will provide 12 months of warranty period as standard, and provide the new replacement for the defective products which belong to the Seller's responsibility verified by the quality department.

8.3 Inspection Criteria:

8.3.1 Critical defect

Item No.	Inspection content	Judgement
8.3.1.1	Functional defects	No display, abnormal display, short circuit, missing line, off-contrast and chromaticity, Touch Panel non-function
8.3.1.2	Model mixed	Other model mixed

8.3.2 Major defect:

Item No.	Inspection content	Judgement
8.3.2.1	Product indication	Missing model no. and wrong model no. is indicated on the LCM.

File NO.

REV

A/01

<http://www.yes-display.com>

8.3.2.2	Glass cracking	The LCD and touch panel glass crack or breakage
8.3.2.3	Missing component	The function component missing such as connector, cable, etc.

8.3.3 Minor defect (LCD) :

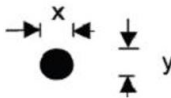
Item No.	Inspection content	Judgement												
8.3.3.1	Black/White spot Foreign particles Dust in the cell	$\varphi = (x+y) / 2$  <table border="1"> <thead> <tr> <th>Diameter (mm)</th> <th>Acceptable Q'ty</th> </tr> </thead> <tbody> <tr> <td>$\Phi \leq 0.1$</td> <td>Ignore</td> </tr> <tr> <td>$0.1 < \Phi \leq 0.25$</td> <td>3 (Distance>5mm)</td> </tr> <tr> <td>$0.25 < \Phi$</td> <td>Not allowed</td> </tr> </tbody> </table>	Diameter (mm)	Acceptable Q'ty	$\Phi \leq 0.1$	Ignore	$0.1 < \Phi \leq 0.25$	3 (Distance>5mm)	$0.25 < \Phi$	Not allowed				
Diameter (mm)	Acceptable Q'ty													
$\Phi \leq 0.1$	Ignore													
$0.1 < \Phi \leq 0.25$	3 (Distance>5mm)													
$0.25 < \Phi$	Not allowed													
8.3.3.2	Linear defect Black/white line Black/white scratch	<table border="1"> <thead> <tr> <th>Length(mm)</th> <th>Width (mm)</th> <th>Acceptable Q'ty</th> </tr> </thead> <tbody> <tr> <td></td> <td>$W \leq 0.03$</td> <td>Ignore</td> </tr> <tr> <td>$L \leq 5.0$</td> <td>$0.03 < W \leq 0.07$</td> <td>3</td> </tr> <tr> <td></td> <td>$0.07 < W$</td> <td>Follow 8.3.3.1</td> </tr> </tbody> </table>	Length(mm)	Width (mm)	Acceptable Q'ty		$W \leq 0.03$	Ignore	$L \leq 5.0$	$0.03 < W \leq 0.07$	3		$0.07 < W$	Follow 8.3.3.1
Length(mm)	Width (mm)	Acceptable Q'ty												
	$W \leq 0.03$	Ignore												
$L \leq 5.0$	$0.03 < W \leq 0.07$	3												
	$0.07 < W$	Follow 8.3.3.1												
8.3.3.3	Polarizer Bubbles Dent on polarizer	<table border="1"> <thead> <tr> <th>Diameter (mm)</th> <th>Acceptable Q'ty</th> </tr> </thead> <tbody> <tr> <td>$\Phi \leq 0.2$</td> <td>Ignore</td> </tr> <tr> <td>$0.2 < \Phi \leq 0.5$</td> <td>2 (Distance>5mm)</td> </tr> <tr> <td>$0.5 < \Phi$</td> <td>Not allowed</td> </tr> </tbody> </table>	Diameter (mm)	Acceptable Q'ty	$\Phi \leq 0.2$	Ignore	$0.2 < \Phi \leq 0.5$	2 (Distance>5mm)	$0.5 < \Phi$	Not allowed				
Diameter (mm)	Acceptable Q'ty													
$\Phi \leq 0.2$	Ignore													
$0.2 < \Phi \leq 0.5$	2 (Distance>5mm)													
$0.5 < \Phi$	Not allowed													

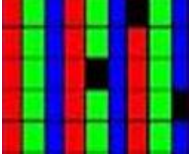
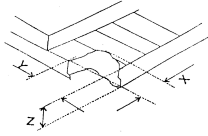
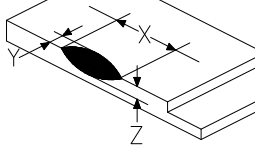
<p>8.3.3.4</p>	<p>Electrical Defect Dot</p>	<p>Bright dot and Dark dot definition:</p>  <p>or</p>  <p>(Two adjacent dot)</p> <p>Inspection pattern: black, white, red, green, and blue screen.</p> <table border="1" data-bbox="730 730 1441 913"> <thead> <tr> <th>Items</th> <th>Acceptable Q'ty</th> </tr> </thead> <tbody> <tr> <td>Bright dot</td> <td>$N \leq 4$ (Distance >5mm)</td> </tr> <tr> <td>Dark dot</td> <td>$N \leq 4$ (Distance >5mm)</td> </tr> </tbody> </table>	Items	Acceptable Q'ty	Bright dot	$N \leq 4$ (Distance >5mm)	Dark dot	$N \leq 4$ (Distance >5mm)
Items	Acceptable Q'ty							
Bright dot	$N \leq 4$ (Distance >5mm)							
Dark dot	$N \leq 4$ (Distance >5mm)							
<p>8.3.3.5</p>	<p>Glass Defect- Corner chipping</p>	 <table border="1" data-bbox="730 1104 1441 1379"> <thead> <tr> <th>Size(mm)</th> <th>Judgement</th> </tr> </thead> <tbody> <tr> <td> $X \leq 3\text{mm}$, $Y \leq S$, $Z \leq T$ (S= ITO length, T=Single glass thickness) </td> <td>Accept</td> </tr> </tbody> </table>	Size(mm)	Judgement	$X \leq 3\text{mm}$, $Y \leq S$, $Z \leq T$ (S= ITO length, T=Single glass thickness)	Accept		
Size(mm)	Judgement							
$X \leq 3\text{mm}$, $Y \leq S$, $Z \leq T$ (S= ITO length, T=Single glass thickness)	Accept							
<p>8.3.3.6</p>	<p>Glass Defect- Side fragment</p>	 <table border="1" data-bbox="730 1574 1441 1787"> <thead> <tr> <th>Size(mm)</th> <th>Judgement</th> </tr> </thead> <tbody> <tr> <td> $X \leq 2 \text{ mm}$, $Y \leq \text{border edge}$ $Z \leq T$ (T= single glass thickness) </td> <td>Accept</td> </tr> </tbody> </table>	Size(mm)	Judgement	$X \leq 2 \text{ mm}$, $Y \leq \text{border edge}$ $Z \leq T$ (T= single glass thickness)	Accept		
Size(mm)	Judgement							
$X \leq 2 \text{ mm}$, $Y \leq \text{border edge}$ $Z \leq T$ (T= single glass thickness)	Accept							

8.3.4 Minor defect (Touch Panel)

Item No.	Inspection content	Judgement
----------	--------------------	-----------

File NO.

REV

A/01

<http://www.yes-display.com>

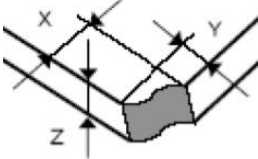
8.3.4.1	Scratch, dust, particles, foreign materials in "linear type"	Size (mm)	Acceptable Q'ty
		$W \leq 0.05\text{mm}, L \leq 10\text{mm}$	Ignore
		$0.05\text{mm} < W \leq 0.07\text{mm}, L \leq 10\text{mm}$	3
		$W > 0.07\text{mm}$	Reject
8.3.4.2	Scratch, dust, particles, foreign materials in "round type"	Diameter (mm)	Acceptable Q'ty
		$\Phi \leq 0.25\text{mm}$	Ignore
		$0.25\text{mm} < \Phi \leq 0.35\text{mm}$	5
		$\Phi > 0.35\text{mm}$	Reject
8.3.4.3	Air bubbles	Diameter (mm)	Acceptable Q'ty
		$\Phi \leq 0.2\text{mm}$	Ignore
		$0.2\text{mm} < \Phi \leq 0.5\text{mm}$	3
		$\Phi > 0.5\text{mm}$	Reject
8.3.4.5	Scratch on printing area	Size (mm)	Acceptable Q'ty
		$W \leq 0.03\text{mm}, L \leq 5\text{mm}$	Ignore
		$0.03\text{mm} < W \leq 0.05\text{mm}, L \leq 5\text{mm}$	3
		$W > 0.05\text{mm}$ or $L > 5\text{mm}$	Reject
8.3.4.6	Corner chipping		
		Size(mm)	Judgement
		$X \leq 2\text{mm}, Y \leq 2\text{mm}$ $Z < 1/2T$ (T= single glass thickness)	Accept

8.3.4.7

Edge chipping

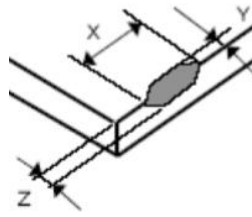

Size(mm)	Judgement
$X \leq 3 \text{ mm}$, $Y \leq 3 \text{ mm}$ $Z \leq 1/2 T$ (T= single glass thickness)	Accept

深圳市亿显国际科技有限公司 ShenZhen Yes-Display International Technology CO.,LTD.			1.44 寸液晶显示屏 1.44 Inch LCD Display Screen	
File NO.		REV	A/01	http://www.yes-display.com

9. Reliability Test Conditions and Methods

9.1 Reliability Test Conditions and Methods:

NO.	TEST ITEMS	TEST CONDITION	INSPECTION AFTER TEST
①	High Temperature Storage	80°C±2°C×96Hours	Inspection after 2~4hours storage at room temperature, the samples should be free from defects: 1, Air bubble in the LCD. 2, Seal leak. 3, Non-display. 4, Missing segments. 5, Glass crack. 6, Current IDD is twice higher than initial value. 7, The surface shall be free from damage. 8, The electric characteristic requirements shall be satisfied.
②	Low Temperature Storage	-30°C±2°C×96Hours	
③	High Temperature Operating	70°C±2°C×96Hours	
④	Low Temperature Operating	-20°C±2°C×96Hours	
⑤	Temperature Cycle(Storage)	$ \begin{array}{c} -20^{\circ}\text{C} \longleftrightarrow 25^{\circ}\text{C} \longleftrightarrow 70^{\circ}\text{C} \\ (30\text{min}) \longleftarrow (5\text{min}) \longrightarrow (30\text{min}) \\ \text{1cycle} \\ \text{Total 10cycle} \end{array} $	
⑥	Damp Proof Test (Storage)	50°C±5°C×90%RH×96Hours	
⑦	Vibration Test	Frequency:10Hz~55Hz~10Hz Amplitude:1.5MM X,Y,Z direction for total 3hours (packing condition test will be tested by a carton)	
⑧	Drooping Test	Drop to the ground from 1M height one time every side of carton. (packing condition test will be tested by a carton)	
⑨	ESD Test	Voltage:±8KV,R:330Ω,C:150PF,Air Mode,10times	

深圳市亿显国际科技有限公司 ShenZhen Yes-Display International Technology CO.,LTD.			1. 44 寸液晶显示屏 1.44 Inch LCD Display Screen	
File NO.		REV	A/01	http://www.yes-display.com

REMARK:

- 1, The Test samples should be applied to only one test item.
- 2, Sample side for each test item is 5~10pcs.
- 3, For Damp Proof Test, Pure water(Resistance > 10MΩ) should be used.
- 4, In case of malfunction defect caused by ESD damage, if it would be recovered to normal state after resetting, it would be judge as a good part.
- 5, EL evaluation should be accepted from reliability test with humidity and temperature: Some defects such as black spot/blemish can happen by natural chemical reaction with humidity and Fluorescence EL has.
- 6, Failure Judgment Criterion: Basic Specification Electrical Characteristic, Mechanical Characteristic, Optical Characteristic.

深圳市亿显国际科技有限公司 ShenZhen Yes-Display International Technology CO.,LTD.			1.44 寸液晶显示屏 1.44 Inch LCD Display Screen	
File NO.		REV	A/01	http://www.yes-display.com

10. Cautions and Handling Precautions

10.1 Mounting method

The LCD panel of TFT module consists of two thin glass plates with polarizes which easily be damaged. And since the module in so constructed as to be fixed by utilizing fitting holes in the printed circuit board.

Extreme care should be needed when handling the LCD modules.

10.2 Caution of LCD handling and cleaning

When cleaning the display surface, Use soft cloth with solvent

[Recommended below] and wipe lightly

- Isopropyl alcohol
- Ethyl alcohol

Do not wipe the display surface with dry or hard materials that will damage the polarizer surface.

Do not use the following solvent:

- Water
- Aromatics

Do not wipe ITO pad area with the dry or hard materials that will damage the ITO patterns

Do not use the following solvent on the pad or prevent it from being contaminated:

- Soldering flux
- Chlorine (Cl) , Sulfur (S)

If goods were sent without being silicon coated on the pad, ITO patterns could be damaged due to the corrosion as time goes on.

If ITO corrosion happen by miss-handling or using some materials such as Chlorine (Cl), Sulfur (S) from customer, Responsibility is on customer.

10.3 Caution against static charge

The LCD module use C-MOS LSI drivers, so we recommended that you:

Connect any unused input terminal to power or ground, do not input any signals before power is turned on, and ground your body, work/assembly areas, and assembly equipment to protect against static electricity.

深圳市亿显国际科技有限公司 ShenZhen Yes-Display International Technology CO.,LTD.			1.44 寸液晶显示屏 1.44 Inch LCD Display Screen	
File NO.		REV	A/01	http://www.yes-display.com

10.4 packing

- Module employs LCD elements and must be treated as such.
- Avoid intense shock and falls from a height.
- To prevent modules from degradation, do not operate or store them exposed direct to sunshine or high temperature/humidity

10.5 Caution for operation

- It is an indispensable condition to drive LCD's within the specified voltage limit since the higher voltage then the limit cause the shorter LCD life.
- An electrochemical reaction due to direct current causes LCD's undesirable deterioration, so that the use of direct current drive should be avoided.
- Response time will be extremely delayed at lower temperature then the operating temperature range and on the other hand at higher temperature LCD's how dark color in them. However those phenomena do not mean malfunction or out of order with LCD's, which will come back in the specified operation temperature.
- If the display area is pushed hard during operation, some font will be abnormally displayed but it resumes normal condition after turning off once.
- Slight dew depositing on terminals is a cause for electro-chemical reaction resulting in terminal open circuit.

Usage under the maximum operating temperature, 50%Rh or less is required.

10.6 storing

In the case of storing for a long period of time for instance, for years for the purpose or replacement use, the following ways are recommended.

- Storage in a polyethylene bag with the opening sealed so as not to enter fresh air outside in it. And with no desiccant.
- Placing in a dark place where neither exposure to direct sunlight nor light's keeping the storage temperature range.
- Storing with no touch on polarizer surface by the anything else.

[It is recommended to store them as they have been contained in the inner container at the time of delivery from us

10.7 Safety

- It is recommendable to crash damaged or unnecessary LCD's into pieces and wash off liquid crystal by either of solvents such as acetone and ethanol, which should be burned up later.

深圳市亿显国际科技有限公司 ShenZhen Yes-Display International Technology CO.,LTD.			1.44 寸液晶显示屏 1.44 Inch LCD Display Screen	
File NO.		REV	A/01	http://www.yes-display.com

- When any liquid leaked out of a damaged glass cell comes in contact with your hands, please wash it off well with soap and water

11. Packing Method

11.1 Method

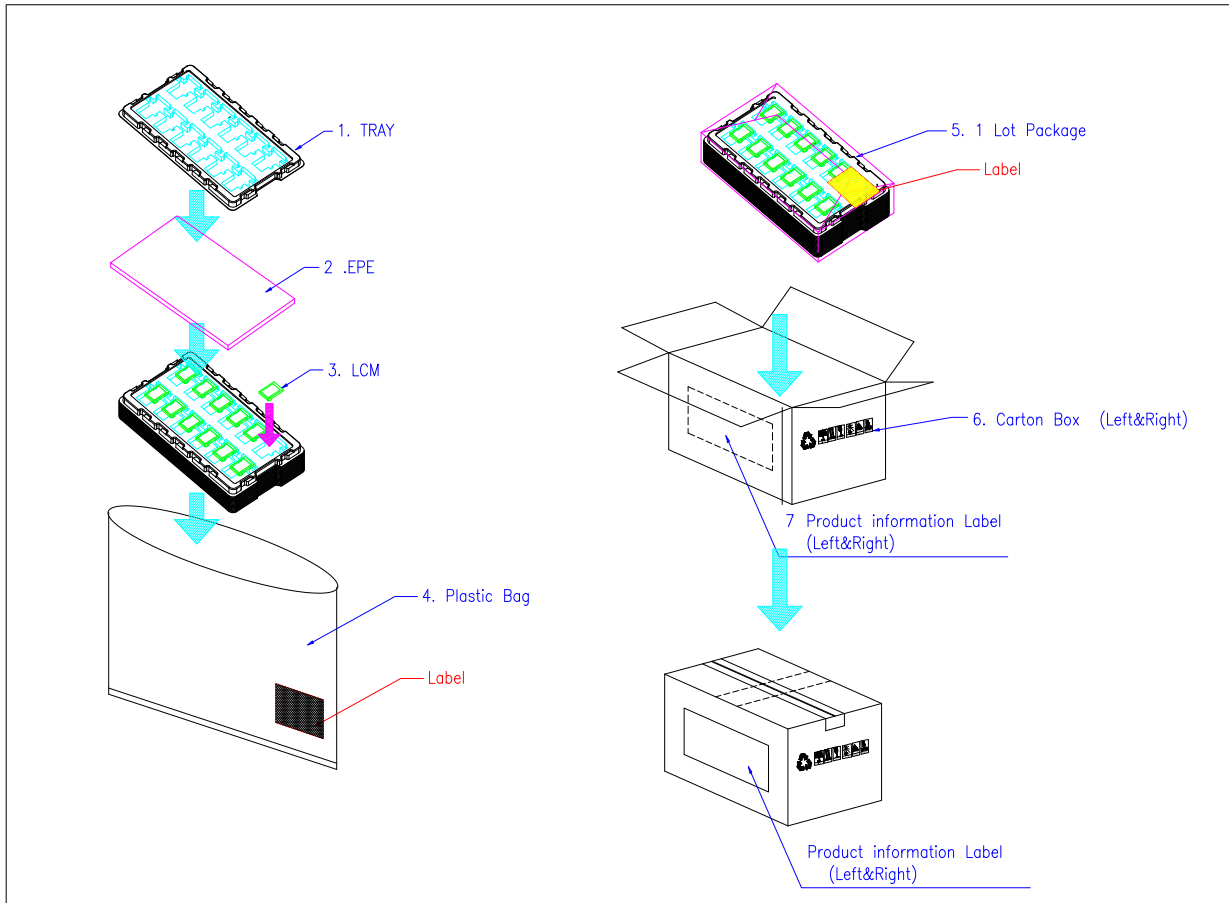

11.2 Packing Label

深圳市亿显国际科技有限公司 ShenZhen Yes-Display International Technology CO.,LTD.			
产品装箱单/Packing List			
型号 Model		数量 Numbers	
订单号 Order Number		日期 Date	
客户编号 Customer Number		检验员 Inspector	
备注 Remarks			